



Visualizing Kinematics: Investigating the Impact of Altered Joint Angles on End-Effector Position and Orientation using Rviz and WidowX250-6DOF

Hassan Ali Obied¹, Dr. Manaf H.Kadhumi¹, Dr. Ali Fawzi AbdulKareem²

Affiliation

¹ College of Engineering
Electrical Engineering
Department,
University of Wasit,
Wasit ,Iraq.

²Technical Institute- Suwaira,
Middle Technical University,
Wasit, Iraq

Correspondence

Hassan Ali Obied,
Electrical Engineering
department,
University of Wasit,
Wasit ,Iraq.

[Email](mailto:hassaina302@uowasit.edu.iq)

hassaina302@uowasit.edu.iq

Received

25-October-2023

Revised

16-November-2023

Accepted

13-December-2023

Doi: [10.31185/ejuow.Vol12.Iss2.477](https://doi.org/10.31185/ejuow.Vol12.Iss2.477)

Abstract

In recent years, the fields of robotics have witnessed major developments, and simulation tools have played an important role in facilitating research and development.

The WidowX250-6DOF robotic arm and the Rviz visualization tool are used in this study to look at how altering joint angles affects the position and orientation of the end-effector. The main goal of this study is to incorporate ROS on a Linux platform in order to give the widowX-250 a simulation environment. Important tasks like the application of forward, position/trajectory control and inverse kinematics should be enabled by this platform. ROS, together with Gazebo, RViz, and MoveIt, are crucial technologies for this project. The goal of this research is to gain a better understanding of how variations in joint angles impact the positioning and orientation of the robot's end-effector. The research helps to improve robotic arm control tactics and applications in many different industries, including manufacturing, automation, and robotics.

Keywords: WidowX 250; 6DOF; Rviz; changing joint angles; ROS

الخلاصة: في السنوات الأخيرة، شهدت مجالات الروبوتات تطورات جوهرية، حيث أصبحت أدوات المحاكاة أداة أساسية في تسهيل البحث والتطوير. يُستخدم ذراع الروبوت WidowX 250-6DOF وأداة التصوير والتصوير البصري المعروفة باسم "Rviz". في هذه الدراسة لاستكشاف تأثير تغيير زوايا المفاصل على موقع واتجاه الجهاز النهائي. هدف هذه الدراسة الرئيسي هو دمج نظام ROS على منصة لينكس لإمكانية توفير بيئة محاكاة لروبوت WidowX 250-6DOF. من المتوقع أن يُمكن هذا النظام المهام الهامة مثل التحكم في الموقع والمسار، وتطبيق الحسابات الحركية لذراع الامامية والعكسية. تعتبر تقنيات ROS بالاشتراك مع Gazebo و RViz و MoveIt أمورًا حيوية في نظام ROS. هدف هذا البحث هو تحقيق فهم أعمق لكيفية تأثير تغيير زوايا المفاصل على موقع واتجاه النهاية المؤثرة للروبوت. سيسهم هذا البحث في تحسين استراتيجيات التحكم بالأذرع الروبوتية وتطبيقاتها في مجموعة متنوعة من الصناعات، بما في ذلك التصنيع والأتمتة وعلم الروبوتات. من خلال هذا البحث، سيكون بوسعنا تقديم نوع جديد من التقنيات الحديثة تفتح آفاقًا جديدة أمام مستقبل الهندسة الروبوتية.

1. INTRODUCTION

Robotics is a modern field of current technology that extends beyond traditional technical limitations in industrial applications. A thorough grasp of robots and their uses necessitated a background in (mechanical, electrical, systems and industrial engineering, economics, computer science, and mathematics) [1]. Manipulator of robotic arm has emerged with a wide range of applications as versatile. Likely for humans, robot such as robotic arm manipulator is experts at performing dangerous, repetitive and tedious jobs. Their ability to perform repetitive, precise tasks has led to increase productivity and efficiency in different applications. Robot has significantly improved productivity, quality and efficiency and an integral part of modern industrial process while reducing workplace accidents and human error [2] [3] [4].

Robotic arm manipulator is heavily used in the production of aerospace applications. The quality, accuracy and productivity a robot can deliver is unmatched aerospace department [4]. Furthermore, the robotic arm is referred to as the manipulator, and a redundant manipulator robot is made up of links connected by joints, much like a chain.

Manipulator motion without force and torque perception are used to depict kinematics difficulties. In summary, the IK challenge of the robot was to determine the values of the joint positions given the EE's position and orientation. Because of its advantages such as (high efficiency, accurately repeated movements, and carrying capacity), the robotic arm system was widely utilized in processing product transportation, production, domestic services, and others [2,3]. Wasit university recently purchased a Trossen Robotics Widow X 250-6 DoF robotic arm.

The study employs Rviz, a robust 3D visualization tool extensively used in the field of robotics, to comprehend how changes in joint angles affect the end-effector's location and orientation of the WidowX250-6DOF robotic arm [4]. Rviz is a graphical representation of robot data that allows users to visualize the robot arm's position as well as preview joint and gripper angles [5]. The WidowX250-6DOF Robot Arm is intended for educational and research use, and it supports ROS (Robot Operating System), Move it, Gazebo, and MATLAB. It has 6 degrees of freedom and a payload capacity of 250g, making it appropriate for a wide range of robotics research and experimentation applications. Researchers can acquire important insights into the consequences of different joint angles on the arm's end-effector by using Rviz in conjunction with the WidowX250-6DOF robotic arm. This knowledge can be used to improve the arm's movement, performance, and capacities in a variety of tasks and applications [6].

Our ongoing work is related to the orientation and position of the arm and has been motivated by the Mechanical engineering and designed and built at the mechanical engineering. Also, this paper focuses on how a visualization software of robotic arm. This paper is organized as follows. In section 2, the experimental part provided in this paper. Section 3 describes the kinematic model of the arm In section 4, the results and discussion conducted to analyse and validate the proposed angles and position. Finally, in section 5, the conclusions of this paper are presented.

2. EXPERIMENTAL PART

The section provides detailed specifications of a Trossen Robotics Widow X 250-6 DoF robotic arm. With support for Robot Operating System (Noetic and Melodic), Gazebo, Melodic and MATLAB, the WidowX 250-6DOF Robot Arm, as depicted in figure (1), is designed for research and education. Demos and instructional tutorials will help you get up and running with your platform in under an hour. The WidowX 250 6DOF has a payload capacity of 250g and six degrees of freedom. Figure (2) depicts the WidowX 250-6DOF Robot Arm's dimensions. By making the central open-source code repository easy to transfer concepts from one platform to another for operating the arms of XSeries. For the best classroom, the WidowX 250 6DOF is perfect for applications such as artificial intelligence, place, machine learning and vision-based pick. The WidowX 250 six degrees of freedom comes tested and fully assembled and is built from extremely rigid 20mm x 20mm extruded Aluminium construction and Aluminium. The arm sits on a slewing bearing and industrial grade for added accuracy and stability. A transparent acrylic shield has been placed over the electronics to protect them from both debris and impact from the arm. The arm consists of hardware and software. The hardware consists of (dynamixel servos, range and 3D print custom end effectors). WidowX 250 6DOF arrives fully assembled and fully tested, housed in an extremely rigid 20mm x 20mm extruded aluminium construction. The industrial grade bearing for accuracy and stability is used in the armrests. Shields of transparent acrylic cover the freeing, electronics them from debris and impact coming from the arm itself. WidowX-250 6DOF boasts 6 degrees of freedom coupled with a full 360° rotation. This number of DOF increases manoeuvrability. While the 6DOF arm can control every factor independently, at least one must be compromised with lower DOF arms. Table (1) shows the specifications of WidowX 250 6DoF. Also, the specifications of joints of WidowX 250 6DoF are shown in table (2). Table (3) illustrates the specifications of Dynamixel XL430-W250T [6].

Robotic arm is used in assembly lines to pick the component of products to be assembled and place and fit them. The WidowX250-6DOF robotic arm and the Rviz visualization tool are used in this work to consider at how altering joint angles affects the position and orientation of the end-effector. To the best knowledge of the authors, there are no studies that directly use the product of exponential to solve the optimization problem of WidowX250-6DOF robotic arm considering a task and a general robotic arm. The problem investigated is to determine the position and orientation of the Widow X250 6DOF robotic arm. The Visualizing Kinematics objective is to define the Impact of Altered Joint Angles on End-Effector Position and Orientation using Rviz and WidowX250-6DOF robotic arm. To simulate the dynamic behavior of the WidowX250-6DOF robotic arm is employed, that is a software product from Interbotix that enables online programming using a standard Windows PC and simulation of robot systems. Basically, the position and orientation to the manipulator arm can be characterized by using Rviz. Based on this idea, the angles of the joints are determined.

Referring to figure (1), the structural design of WidowX 250-6DOF Robot Arm is manufactured. Also, according to figure (1), the WidowX 250-6DOF robot arm consists of:

1. Base
 2. Shoulder
 3. Links
 4. Wrist-Pitch
 5. Wrist-Roll
 6. Gripper
- Dynamixel Servos- The X-series of dynamixel smart servo offers properties that would normally only be determined on level motors of industrial for a fraction of the price.
 - Range- The robot arm of viperX300 has a total span of 150cm with a 75cm horizontal reach from gripper to center of the base. The viperX 300 arm has a working payload of 750g. Also, the viperX 300 can lift more than 750g, Trossenrobotics recommend do not payloads over this number. The weight in which the arm is defined as working payload and is measured by the arms ability to repeatedly lift an object at roughly half extension without failure and should not exceed under normal working circumstances.
 - 3D Print Custom End Effectors- The gripper of X-series carriage is designed for persons to easily and quickly change the gripper fingers for different projects.

Table 1. The specifications of WidowX 250 6DoF [6].

Degree of freedom	6
Reach	650 mm
Span	1300 mm
Recommended workspace	910 mm
Min. grip width	30 mm
Max. grip width	74 mm
Power supply	12V5A
Repeatability	1 mm
Working payload	250g
Total servos	9
Wrist rotate	yes
weight	6.2lbs

Table 2. The specifications of joints of WidowX 250 6DoF [6].

Waist	<i>Min:</i> - 180, <i>Max:</i> 180
Shoulder	<i>Min:</i> - 108, <i>Max:</i> 114
Elbow	<i>Min:</i> - 123, <i>Max:</i> 92
Wrist angle	<i>Min:</i> - 100, <i>Max:</i> 123
Forearm roll	<i>Min:</i> - 180, <i>Max:</i> 180
Wrist rotate	<i>Min:</i> - 180, <i>Max:</i> 180

Table3. specifications of the Dynamixel XL430-W250T.

MCU	ARM CORTEX-M3 (72 [MHz], 32Bit)
POSITION SENSOR	Contactless absolute encoder (12Bit, 360 [°])
Motor	Cored
Baud rate	9,600 [bps] ~ 4.5 [Mbps]
Control Algorithm	PID
Resolution	4096 [pulse/Rev]
weight	57.2g
Gear ratio	258.5:1
Stall torque	1.5N.m at (12V, 1.4A)
No load speed	61Rev/min at 12V

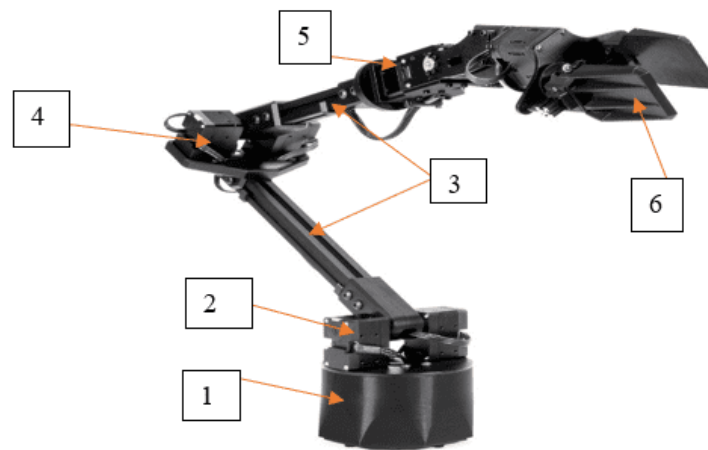

Figure 1. WidowX 250-6DOF Robot Arm.

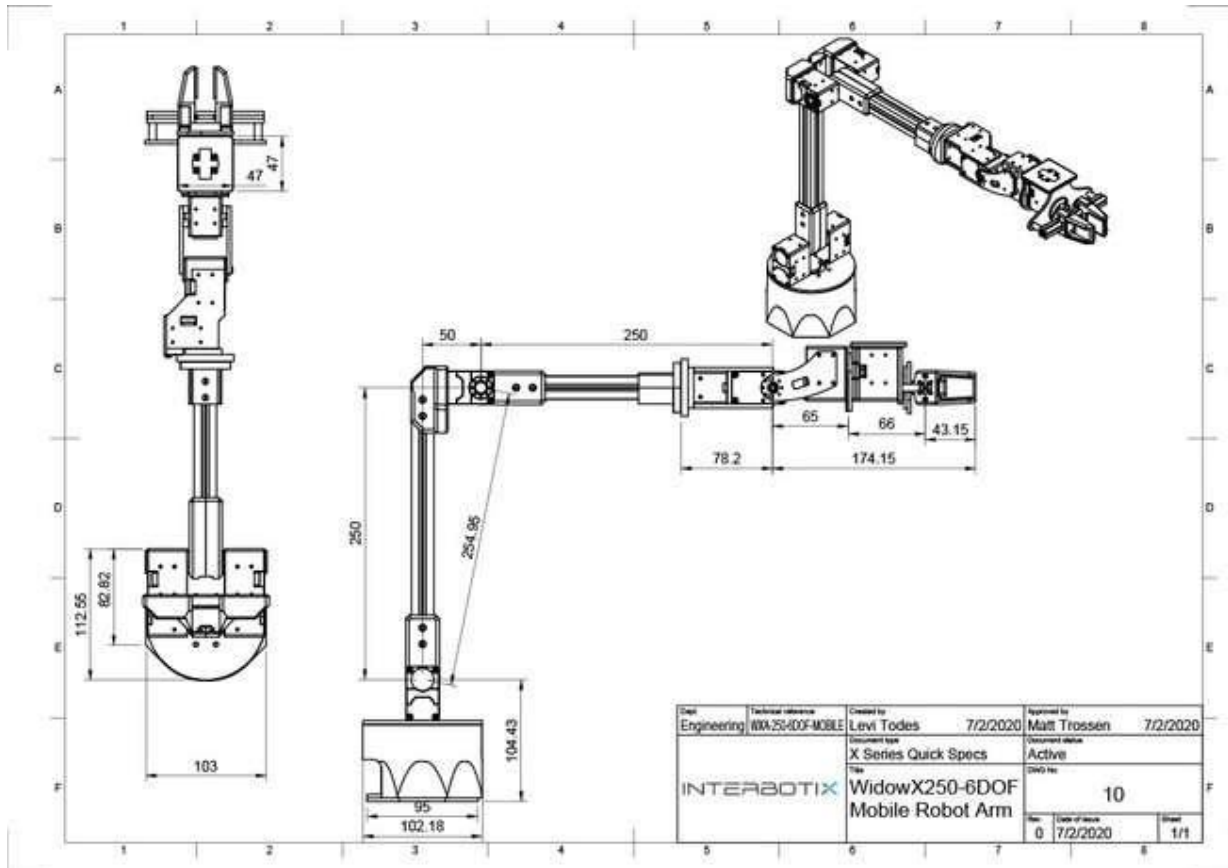

Figure 2. Dimensions of the WidowX 250-6DOF Robot Arm [6].

2.1. Software

X-Series arms make concept transfer over platforms easier and which operate on a similar central open-source repository. Some package modifies working with the arm, like the ROS2 (Humble, Rolling and Galactic) and the ROS (Noetic and Melodic). Package allows smooth integration of lower-level actuator ROS wrappers into higher-level codes and contains motion planning (MoveIt), full simulation (Gazebo), meshes, and URDFs—a driver node controlling the publishing joint states and physical arm. Meanwhile, Interbotix Research Robotics Open Standard IRROS. Additionally, the manipulation software MoveIt is given its BSD license and free for industrial, commercial, and research. Firstly, Gazebo, free software in an active community, can accurately and efficiently simulate robot populations in complex environments. On the other hand, Python-ROS APIs and MATLAB-ROS sit about granting control of the arm and the ROS layer despite lacking familiarity with ROS. Both APIs have the same functionalities for interacting with the arm kinematics, timing parameters, operating mode and among others [6].

This section focuses, step by step, the software engineering best practices as applied to software of robotic. It describes workflows, ROS and ROS2 tools. To illustrate the software of the robotic arm, a simple ROS2C++ node will be characterized. Robot Operating System (ROS or ros) is an open-source robotics middleware suite. Also, ROS is not an operating system (OS) and a set of software frameworks for robot software development, it provides services designed for a heterogeneous computer cluster such as low-level device control, hardware abstraction, message-passing between processes, implementation of commonly used functionality and package management. Running sets of Robot Operating System are represented in a graph architecture and based processes where processing takes place in nodes that may receive, post, and multiplex sensor data, control, state, planning, actuator, and other messages. Despite the importance of reactivity, ROS is *not* a real-time operating system (RTOS) and low latency in robot control,. However, it is possible to integrate Robot Operating System with determining commands. The lack of support for real-time systems has been addressed in the creation of ROS 2, a major revision of the ROS API which will take technologies for core Robot Operating System functions, advantage of modern libraries and embedded system hardware and add support for real-time code.

Visualization techniques help reduce analysis, have proven to be of great educational value and study time while allowing deeper understanding of the material under study [7]. A software packaged named xsarm description [6],

used by authors translates a robot manipulation mathematical model. The structure of the xsarm is shown in figure (3).

This package as shown in figure (3) contains the `xsarm_description.launch` file responsible for loading parts or all of the robot model. It launches up to four nodes as described below [6]:

- `joint_state_publisher` - responsible for parsing the 'robot_description' parameter to publish a Joint State message with those joints defined and determine all non-fixed joints.
- `joint_state_publisher_gui` - allows a user to easily manipulate the joints but does the same thing as the 'joint_state_publisher' node but with a GUI.
- `robot_state_publisher` - uses the URDF specified by the joint positions and the parameter `robot_description` from the `joint_states` topic to publish the results via `tf`, after to find the forward kinematics of the robot
- `rviz` - considers the virtual robot model using the transforms in the 'tf' topic.

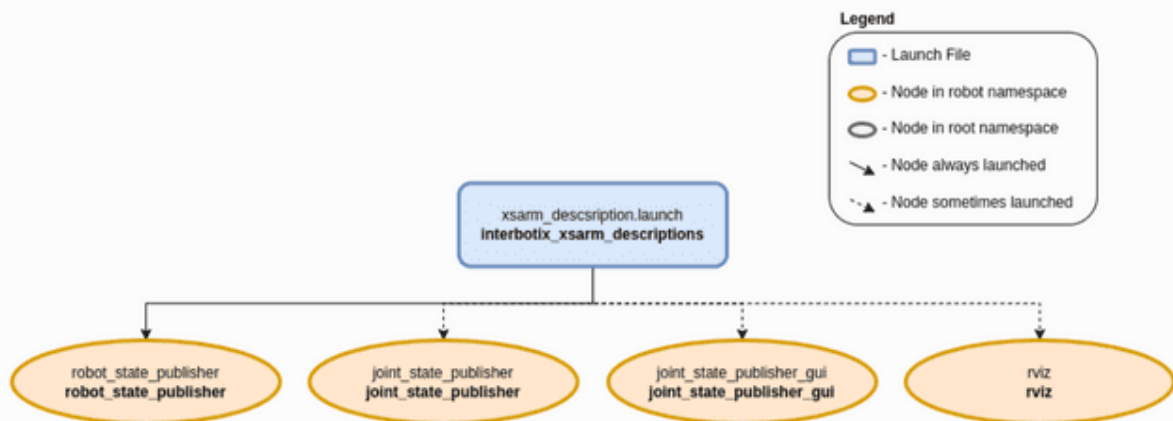

Figure 3. Structure of xsarm [6].

The guide of ROS2 is intended to find the use popular with the basic interfaces and functions interface as illustrated below [6]:

1. Obtain popular with the model of virtual robot by playing with the joint state publisher and launching it in Robot visualization RViz. Also, you must indicate as a command line option which arm model is being utilized.
2. Obtain popular with the physical robot arm.
3. By default, to torque off all the motors, execute the command in another terminal and all the motors in the robot are torqued on so it will be very difficult to manually manipulate it.
4. Now you should be able to freely manipulate the gripper and the arm. Afterwards, take note of how the visualization of robot model precisely the real robot mimics.
5. Let go and watch to see if the arm maintains its position.
6. Shutdown all nodes by pressing CTRL+C after holding on to the robot and in the terminal where you started the launch file.
7. Launching the interbotix xsarm joy package is another approach to verify that all functions operate as intended.

3. KINEMATIC MODEL

POE (product of exponentials) methods are a convention of robotic for mapping a kinematic chain of the links of spatial. It is an alternative to parameterization of Denavit–Hartenberg [8]. The former method uses the fewest number of parameters to represent joint motions, whereas the latter approach has several advantages, including revolute joints, uniform treatment of prismatic, an easy geometric interpretation from the use of screw axes for each joint and definition of only two reference frames. The POE (product of exponentials) for a kinematic chain is determined via the methods described below with the aim of parameterizing an affine transformation matrix between the tool frames in terms of the joint angles and base. zero configuration is the first step where all the joint angles are defined as being zero. The 4×4 matrix $g_{st}(0)$ characterized the transformation from the tool frame in this configuration to the base frame. It is a consisting of affine transform of the 1×3 translation vector p and the 3×3 rotation matrix R . The 4×4 square matrix is created. Paden–Kahan solved the inverse kinematics for most common robot manipulators with the use subproblems. With the use of nonlinear root-finding methods, inverse kinematics problem can also be approached such as the (Newton's method) Newton-Raphson iterative method. Forward kinematics allows generating of complex trajectories of the end-effector in Cartesian space (Cartesian coordinate system) given trajectories in the joint space. It may be determined directly from the product of exponential chain for a given manipulator [9-10].

$$g_{st}(0) = \begin{bmatrix} R & p \\ 0 & 1 \end{bmatrix} \quad (1)$$

$$M = \begin{bmatrix} 1.0 & 0.0 & 0.0 & 0.458325 \\ 0.0 & 1.0 & 0.0 & 0.0 \\ 0.0 & 0.0 & 1.0 & 0.36065 \\ 0.0 & 0.0 & 0.0 & 1.0 \end{bmatrix} \quad (2)$$

$$S_{list} = \begin{bmatrix} 0.0 & 0.0 & 1.0 & 0.0 & 0.0 & 0.0 \\ 0.0 & 1.0 & 0.0 & -0.11065 & 0.0 & 0.0 \\ 0.0 & 1.0 & 0.0 & -0.36065 & 0.0 & 0.04975 \\ 1.0 & 0.0 & 0.0 & 0.0 & 0.36065 & 0.0 \\ 0.0 & 1.0 & 0.0 & -0.36065 & 0.0 & 0.29975 \\ 1.0 & 0.0 & 0.0 & 0.0 & 0.36065 & 0.0 \end{bmatrix}^T \quad (3)$$

4. RESULTS AND DISCUSSIONS

In this section, the results of the impact of Altered Joint Angles of each joint (1 rad) are presented with the fixed angles of the five remained joints of an arm on the position and orientation of the end effector, and compared to the position and orientation of the end effector at the initial arm pose (Home Position), where all angles of the joints are zero. To validate the position and orientation, the performed experiments with seven cases are carried out. All experiments are performed with the experiment setup and methodology discussed in this section. These cases are first presented visualized in the `xsarm_description_rviz`-RViz software. Table 4 compares EE-Coordinates using the Rviz platform in the ROS of the seven situations inspected in this investigation to EE coordination in the initial arm condition, which was designated case 0. The WidowX-250 robotic arm utilized in the visualization comprises a total of six degrees of freedom. It's physical dimensions are shown in figure (2), weighing around 6.2lbs. The Dynamixel XL430-W250T comprised as illustrated in table (3). The parameters for each joint used in this work are given in table (2). Simulation was conducted to visualize the WidowX-250 robotic arm. All cases were applied to WidowX-250 robotic arm.

Table 4. The EE-coordinates results were obtained using the Rviz - platform.

case	Joint Variable (rad)						EE-Position (m)			EE-Orientation (rad)		
	01	02	03	04	05	06	X	Y	Z	X	Y	Z
0	0	0	0	0	0	0	0.458	0	0.361	0	0	0
1	1	0	0	0	0	0	0.248	0.386	0.361	0	0	0.48
2	0	1	0	0	0	0	0.459	0	-0.138	0	0.477	0
3	0	0	1	0	0	0	0.271	0	0.018	0	0.477	0
4	0	0	0	1	0	0	0.458	0	0.361	0.477	0	0
5	0	0	0	0	1	0	0.386	0	0.228	0	0.478	0
6	0	0	0	0	0	1	0.458	0	0.361	0.479	0	0
7	0	0	0	1	1	1	0.386	0.112	0.289	0.739	0.478	0

Investigation of the table illuminates the following:

- Case 0: the reference case (the initial instance of an arm) against which the subsequent examples will be compared as shown in figure (4).

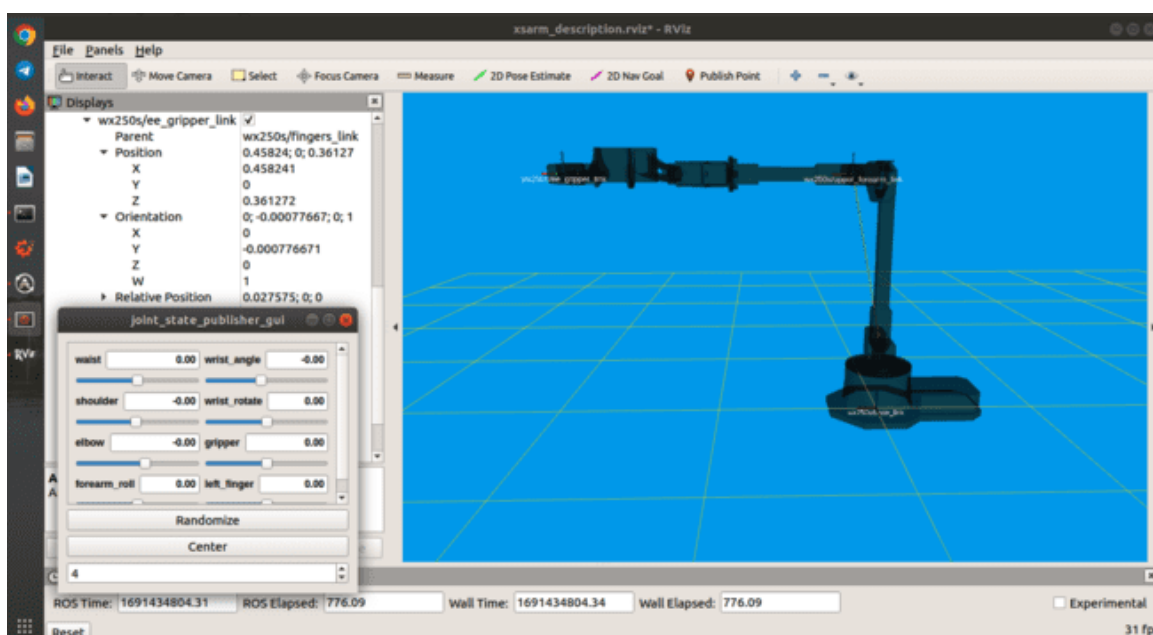

- **Figure 4.** WidowX-250 6DOF home pose.
- Case 1: Because the waist joint serves as the foundation for the other arm joints, a change in the X and Y axes of the EE-coordinate position was observed without a change in the orientation values. Additionally, the direction of the waist joint's angle of rotation in relation to the Z-axis was not changed in this case as illustrated in figure (5).

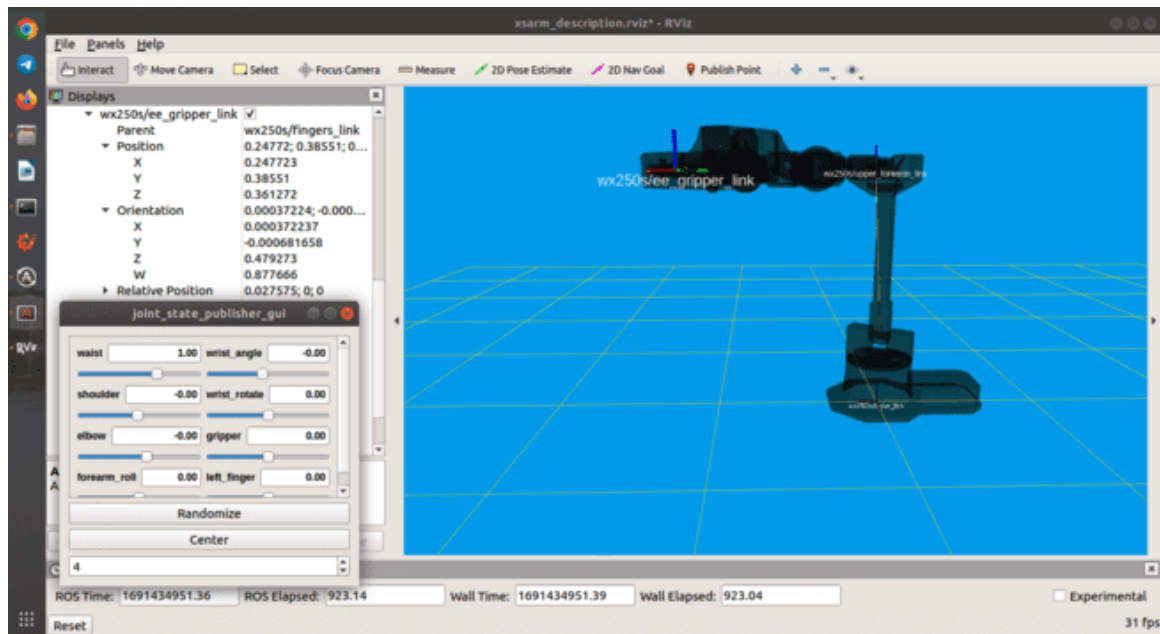

Figure 5. Shown the EE-coordinate for case 1.

- case 2: In this situation, changing the value of the shoulder joint affects all EE_coordinate values on all axes in terms of position and orientation. Figure 6 demonstrates this kind of situation.

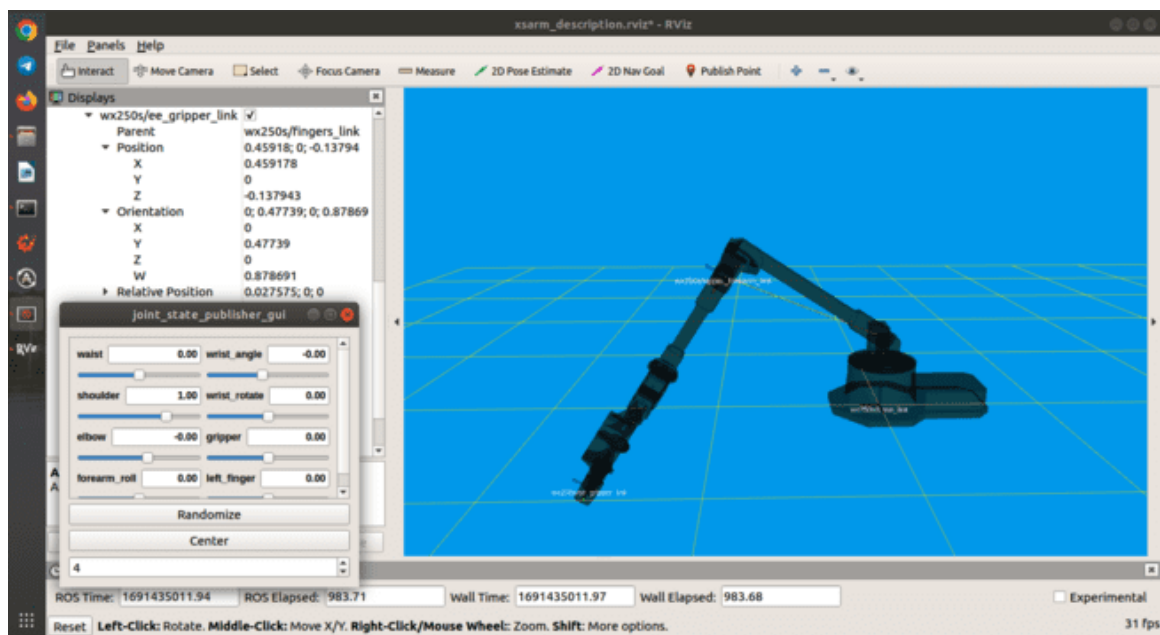

Figure 6. The EE-coordinate for Case 2 is shown.

- case 3: As in the previous scenario, changing the value of the elbow joint causes a change in the EE_coordinate values on all axes regarding position and orientation, depending on the values of the other joints. Figure 7 illustrates this type of state.

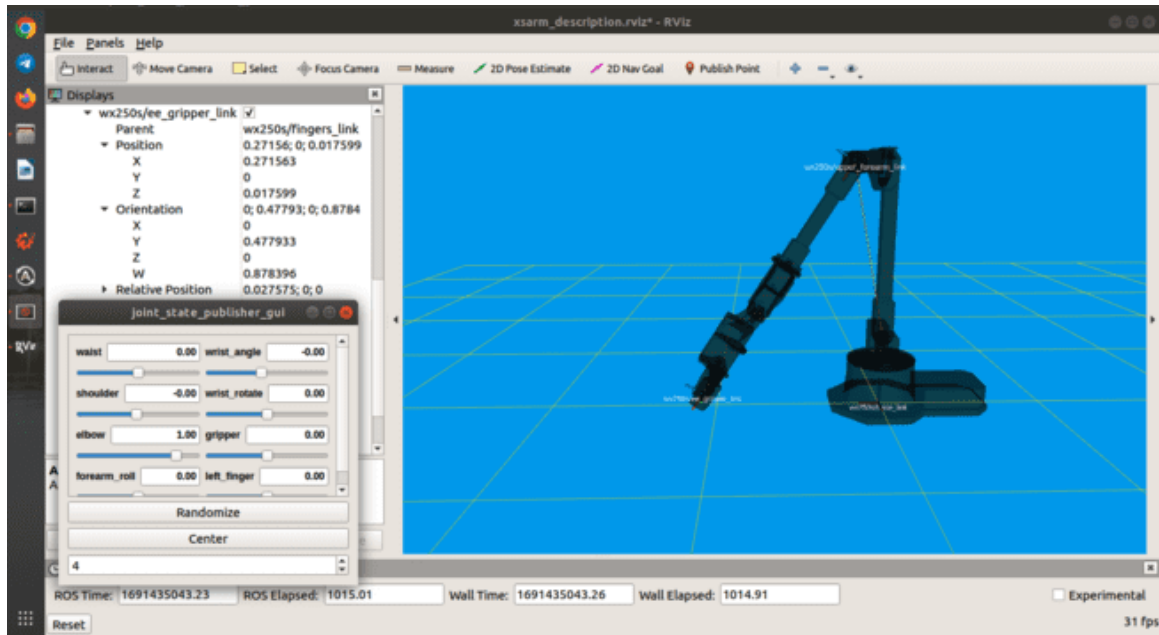

Figure 7. The EE-coordinate for case 3 is presented .

- Case 4: If the angle of the fifth joint is 0, the forearm_roll value has no influence on the end_effector, but it does affect orientation. Figure 8 depicts the arm's placement in this instance.

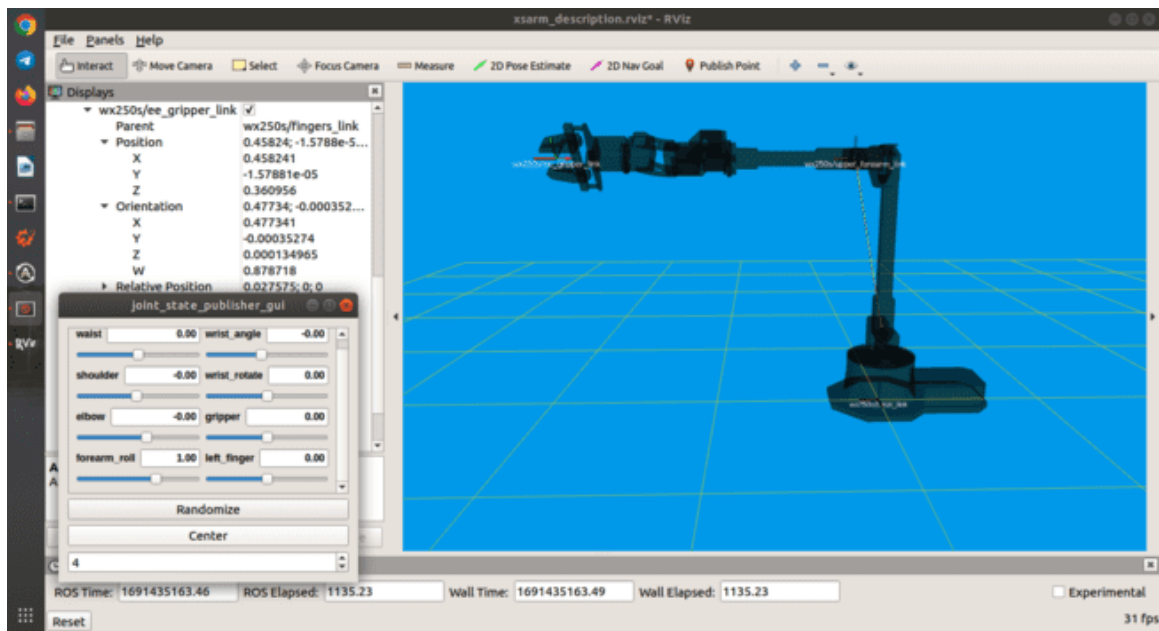

Figure 8. The EE-coordinate for case 4 is presented

- Case 5: Changing the value of the wrist_angle joint impacts all EE_coordinate values on all axes in terms of position and orientation, dependent on the values of the joints before and after it. Figure 9 depicts this sort of scenario.

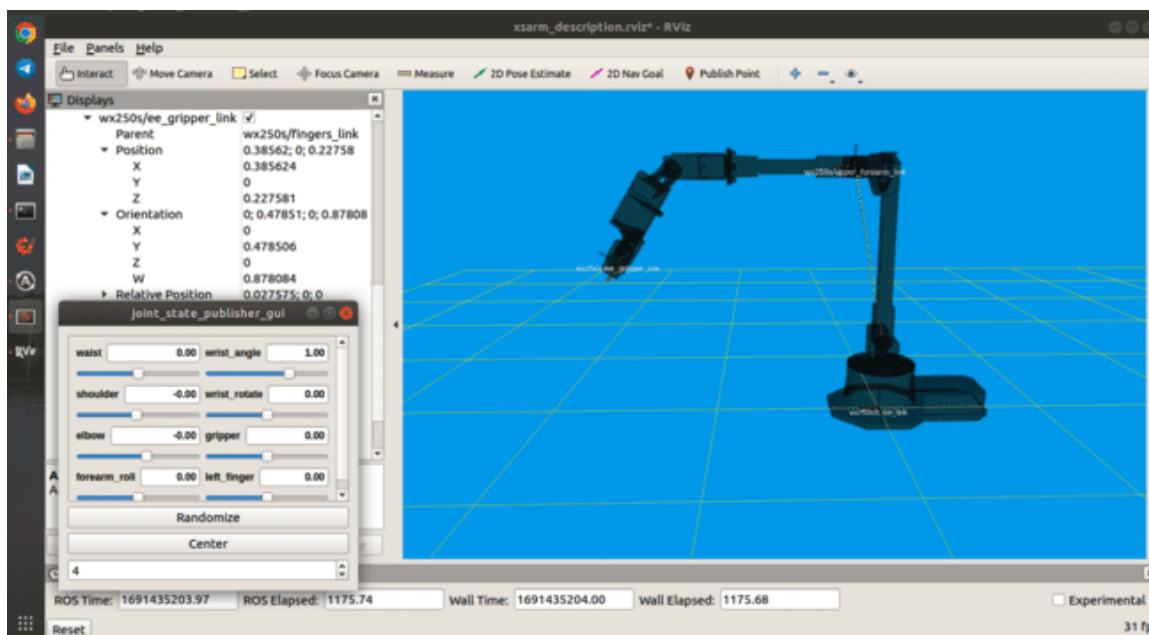

Figure 9. The EE-coordinate for case 5 is presented

- Case 6: Because the wrist_rotate joint is directly attached to the gripper, a change in its joint angle value has no effect on the position of the EE_coordinate but only on its orientation. This is seen in Figure 10.

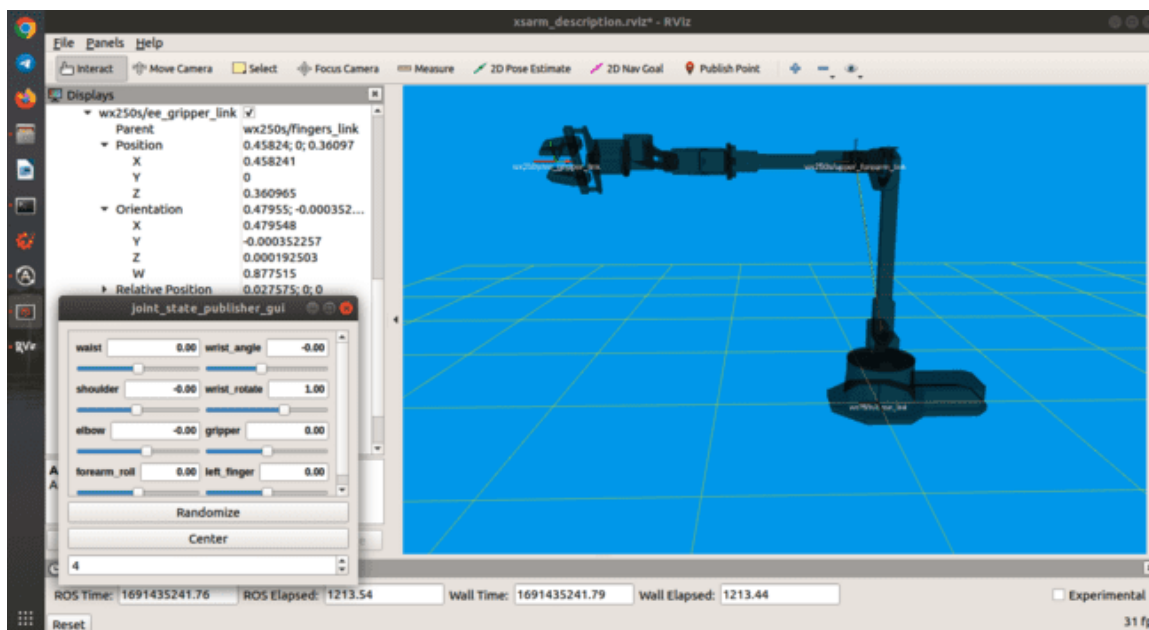

Figure 10. The EE-coordinate for case 6 is presented

- Case 7: Changing the position of joints 4,5, and 6 has an influence on the end-effector stance, explaining what was seen in the fourth and fifth examples. This is seen in Figure 11.

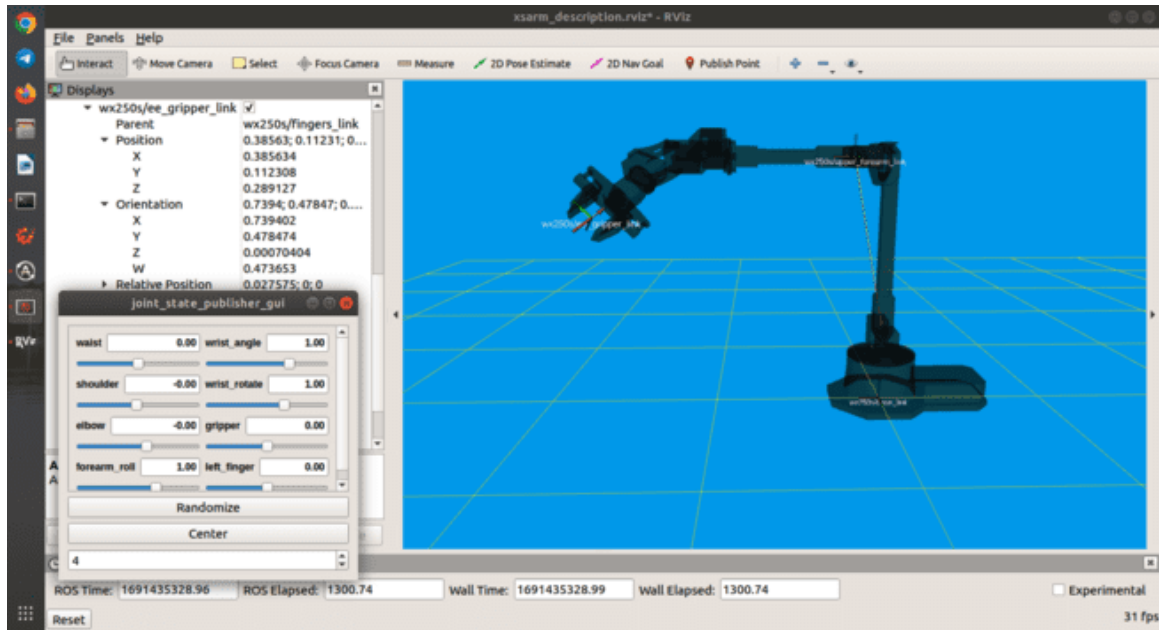

Figure 11. The EE-coordinate for case 7.

The position and orientation were applied for seven cases as defined in the previous section. The widowX250 robotic arm visualization results are shown in figure (12) and (13) for the considered seven cases. It can be seen that the seven cases of the arm is able to reach the defined target. The red line in the plot refers to the X-axis, the green line refers to the Y-axis and the blue line refers to the z-axis for the position and orientation. Hence, figure (12) shows the relation between EE orientation division in radian with number of cases in the X-axis, Y-axis and Z-axis. In the case 1, the orientation of Z-axis is 0.48 radian but zero in the X, Y directions. In case 2 and case 3, the orientations of Y-axis are 0.477 radian but zero in X and Z directions. The orientation of X-axis is 0.477 radian and zero radian in the Y and Z directions in the case 4. Also, the orientation of Y-axis is 0.478 radian and zero radian in the X and Z directions in case 5. On the other hand, the orientation of X-axis is 0.479 radian and zero radian in the Y and Z directions. In case 7, the orientation of X-direction is 0.739 radian, 0.478 radian in Y-axis and zero radian in Z-axis.

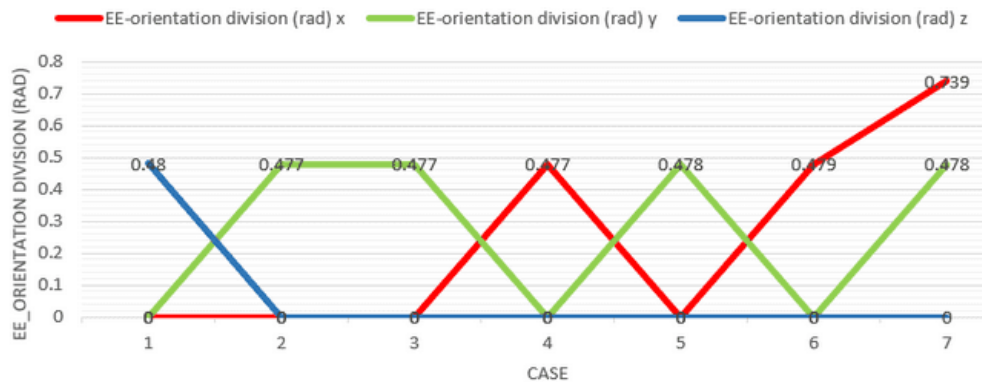

Figure 12. EE orientation division (rad) with case number in three directions.

Figure (13) shows the relationship between the EE_position in the three directions for all cases. In case 1, the position of Z-axis is zero and the position of X-axis is 0.21m and position of Y-axis is 0.386m. In case 2, the position of X-axis is 0.001m, position of Y-axis is zero and the position of Z-axis is 0.499m. However, the position of Y-axis is zero, the position of X-axis is 0.187m in the case 3 and the position of Z-axis is 0.343m. On the other hand, the position of all directions is zero in case 4 and case 6. In case 5, the position of Y-axis is zero and the position of X-axis is 0.072m and Y direction is 0.133m. The positions of the X and Z directions are 0.072m and the position of Y-axis is 0.112 m in the case 7.

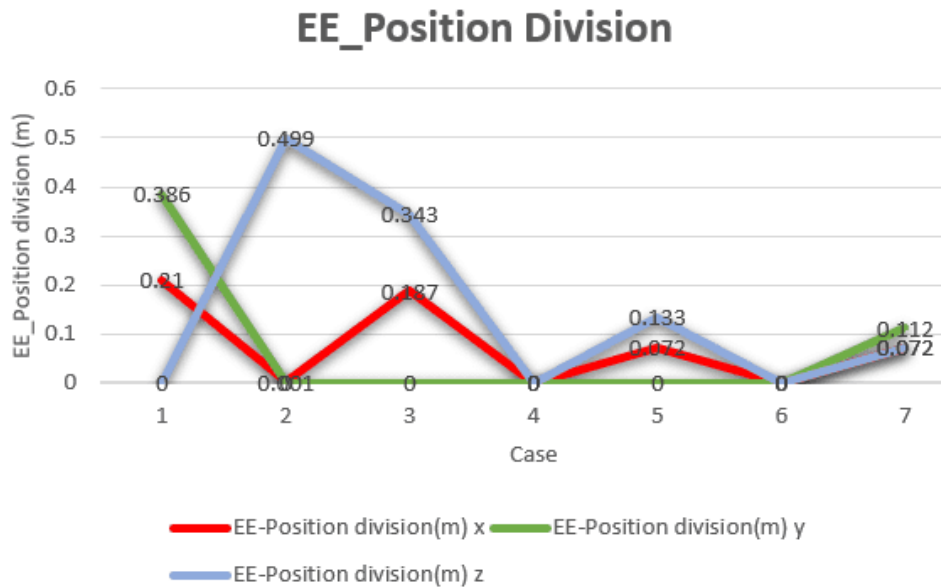

Figure 13. EE position division (m) with case number in three directions.

5. CONCLUSIONS

This research paper presents a detailed investigation into the impact of altered joint angles on the end-effector's position and orientation using Rviz and the WidowX250-6DOF robotic arm. The findings contribute valuable insights into the kinematics of robotic arms and provide a foundation for optimizing joint angles to achieve desired end-effector positions and orientations. The knowledge gained from this study can aid in the development of more efficient and precise robotic arm control strategies.

REFERENCES

1. W. I. M. AL-Tameemi and W. M. H. Hadi, "Kinematics analysis of 5250 lab-volt 5-DoF robot arm," *Eng. Tech. J.*, vol. 32, no. 9, pp. 2196–2204, 2014.
2. P. Corke, "Robotics, vision and control: Fundamental algorithms In MATLAB (Second, completely revised, extended and updated edition)[Springer Tracts in Advanced Robotics, Volume 118]," 2017.
3. J. Ondras, D. Ni, X. Deng, Z. Gu, H. Zheng, and T. Bhattacharjee, "Robotic Dough Shaping," in *2022 22nd International Conference on Control, Automation and Systems (ICCAS), 2022*, pp. 300–307.
4. C. Lauritzen, "Development of a simulation platform and testing of a 5 degrees of freedom ReactorX-150 robotic arm manipulator," *The University of South-Eastern Norway*, 2023.
5. I. Robotics. [Online]. Available: https://classes.cs.uchicago.edu/archive/2022/spring/20600-1/class_meeting_10.html. [Accessed 7 8 2023].
6. W. 2. R. A. 6. -. X.-S. R. Arm. [Online]. Available: <https://www.trossenrobotics.com/widowx-250-robot-arm-6dof.aspx>. [Accessed 7 8 2023].

7. Rachid Manseur, " Visualization Tools for Robotics Education", In: Proceedings of the international conference in engineering education (ICEE) 2004.
8. Brockett, Roger, "Modern Robotics" , (1st ed), Cambridge University Press, 2017.
9. Malik, Ayslan; Henderson, Troy; Prazenica, Richard, " Trajectory Generation for a Multibody Robotic System using the Product of Exponentials Formulation", *AIAA Scitech 2021 Forum*: 2016,2021.
10. Wu, Liao; Crawford, Ross; Roberts, Jonathan, "An Analytic Approach to Converting POE Parameters Into D–H Parameters for Serial-Link Robots", *IEEE Robotics and Automation Letters*. **2** (4): 2174–2179