



## Non-Orthogonal Multiple Access (NOMA) Dynamic Power Allocation in 5G Networks

Noor Mohammed Mohsin<sup>1</sup>, Ismael Sharhan Hubri<sup>1</sup>

### Affiliations

1Department of Electrical Engineering, Wasit University, Wasit, Iraq.

### Correspondence

Noor Mohammed Mohsin,  
Department of Electrical Engineering, Wasit University, Wasit, Iraq  
Email: [nmohson@uowasit.edu.iq](mailto:nmohson@uowasit.edu.iq)

### Received

14-February-2022

### Revised

24-April-2022

### Accepted

26-April-2022

Doi: [10.31185/ejuow.Vol10.Iss2.297](https://doi.org/10.31185/ejuow.Vol10.Iss2.297)

### Abstract

The thought of non-orthogonal multiple access (NOMA) are given as a potential radio access method for versatile correspondence networks past the fourth era (4G). As opposed to current long haul development radio access procedures, non-symmetrical different access involves the power space for client multiplexing at the transmitter and utilizations a successive obstruction dropping recipient as the pattern collector conspire, considering future cell phone advancement. Non-symmetrical different access is feasible to serve various clients simultaneously and recurrence. For 5G wireless communication networks, non-orthogonal multiple access (NOMA) and millimeter wave (mm-Wave) communications are interesting technologies. The performance of partially connected hybrid beamforming (PC-H-BF), a low-cost partially connected hybrid beamforming (H-BF) with a quick convergence sub-optimal power allocation algorithm, was explored in this work. A low-cost hybrid beam forming technique, as well as a dynamic threshold users' grouping mechanism, were created. In addition, to boost information flow, the sub-optimal inert-beam and intra-beam dynamic power allocation tasks are implemented using a low-complexity iterative maximization technique.

**Keywords:** NOMA, Multiple-input multiple-output, Spectral Efficiency, Energy Efficiency, power allocation, average sum rate, millimeter waves.

**الخلاصة:** يتم إعطاء فكرة الوصول المتعدد غير المتعامد (NOMA) كطريقة وصول لاسلكية محتملة لشبكات المراسلات متعددة الاستخدامات ما بعد العصر الرابع (4G). على عكس إجراءات الوصول الراديوي للتطوير الحالي لمسافات طويلة، يتضمن النفاذ المختلف غير المتماثل مساحة القدرة لتعدد إرسال العميل عند جهاز الإرسال واستخدام عائق متتالي يسقط المستلم مع تأمر جامع النمط، مع الأخذ في الاعتبار التقدم المستقبلي للهاتف الخليوي. الوصول المختلف غير المتماثل ممكن لخدمة العديد من العملاء في وقت واحد والتكرار. بالنسبة لشبكات الاتصالات اللاسلكية 5G، تعد اتصالات الوصول المتعدد غير المتعامد (NOMA) والموجة المليمترية (mm-Wave) من التقنيات المثيرة للاهتمام. تم في هذا العمل استكشاف أداء تشكيل الحزمة الهجينة المتصلة جزئياً (PC-H-BF)، وهو عبارة عن تشكيل شعاع هجين منخفض التكلفة متصل جزئياً (H-BF) مع خوارزمية توزيع طاقة دون المستوى الأمثل لتقارب سريع. تم إنشاء تقنية تشكيل شعاع هجين منخفض التكلفة، بالإضافة إلى آلية تجميع عتبة ديناميكية للمستخدمين. بالإضافة إلى ذلك، لتعزيز تدفق المعلومات، يتم تنفيذ مهام تخصيص القدرة الديناميكية للحزمة الحاملة وداخل الحزمة دون المستوى الأمثل باستخدام تقنية تعظيم تكرارية منخفضة التعقيد.

## 1. INTRODUCTION

In recent years, the enormous advancement in the number of remote gadgets associated and those billions of these gadgets are associated by remote organizations, and every gadget needs high efficiency to help different applications like voice, video, and games and supports the increment in the number of gadgets, the number of administrations and the nature of correspondences later on. As a rule, future remote frameworks need to meet three primary necessities Provide high efficiency, Serve numerous clients simultaneously and Provide less energy consumption [1]. Various systems have been adopted in recent years to accomplish these aims, with millimeter-wave networking, a large multiple-input multiple-output system, and non-orthogonal multiple access (NOMA) among the most notable candidates [2]. Millimeter-wave (mmWave) communications, which work at frequencies between 30 and 300 GHz, provide a way to satisfy 5G's explosive capacity requirements [3]. Users' multiplexing can be assisted at the same time/freq./spatial services by superposition coding for transmitters and

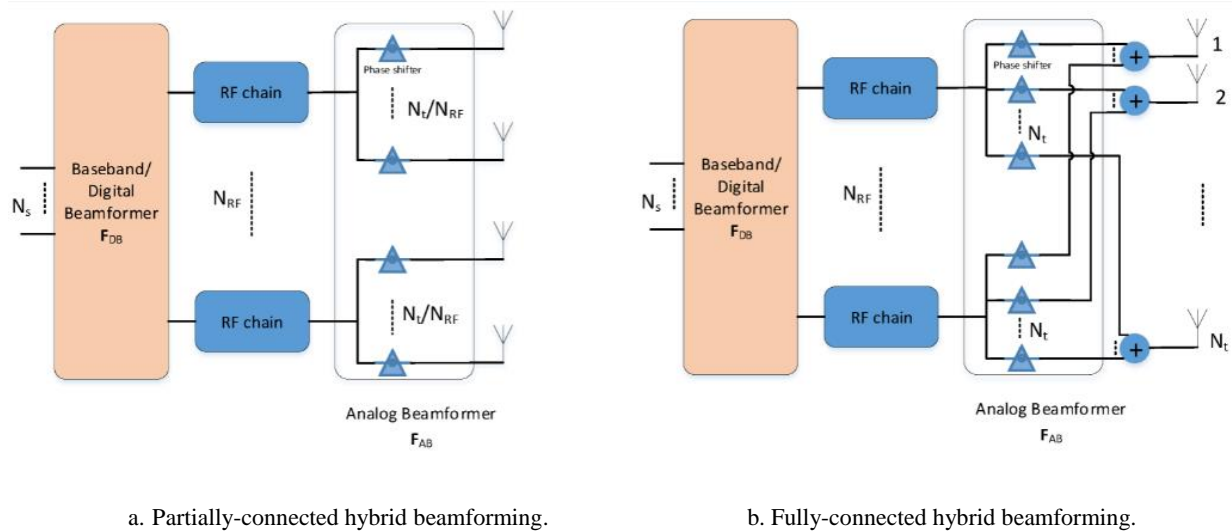
receiver sequential interference cancellation and the variance of channel gain between users' devices can be converted into multiplexing advantage via superposition coding [4].

Significant output gains can be earned by incorporating non-orthogonal multiple access into Millimeter waves. However, even though the developments of the aforementioned can greatly improve wireless networks' spectral performance, they generally Due to the necessity to deploy exponentially more powerful antenna elements and more expensive chains, more energy and hardware are required. for radiofrequency transceivers to operate at higher frequencies.-spectrum. As a result, the question of whether integrating more active components in mobile systems can be a feasible option for potential capacity growth remains open and difficult. Many efforts have been undertaken to reduce gadget complexity and energy use. to overcome this difficult problem. [5]. In such manner, [19] proposes a hybrid NOMA arrangement are separated into in a little groups, NOMA is utilized inside each group, and inter-cluster interference is diminished utilizing MIMO framework discovery strategies. A hybrid non-orthogonal multiple access (NOMA) approach into this discussion. When users are separated into tiny groups, non-orthogonal multiple access (NOMA) is used inside each group, and inter-cluster interference is reduced using multiple input multiple output (MIMO) system detection techniques. Following this, it was realized in [6] that the multi-user precoder system suggested in [3] could be wasteful if user fairness is taken into account. A two-stage precoder technique is introduced in [5] by following the concept of consumer grouping. Within one group, the minimum transmits power is adopted, and zero-forcing was used between groups. By employing the user correlation rather than the cost function, a simpler greedy approach for user pairing is also suggested. Furthermore, every radiofrequency bind is associated with a grouping of receiving wires, the partially linked phase shifter method [7–8] is offered as one possible way to improve hardware performance. A successive interference cancellation (SIC) aided H-BF technique is suggested in [9], which takes advantage of the fact that the analog beamforming matrix of the partially connected network is blocking diagonal. In Ref. [8,] a semi-definite relaxation-aided alternating optimization-formula is proposed, which can increase the performance of the partially linked phase shifter design significantly. Where the number of radio frequency chains meets those requirements, the partially connected phase shifter method outperforms the fully connected phase shifter equivalent in hardware performance, while the spectral efficiency of hybrid beamforming with the partially connected phase shifter scheme underperforms noticeably [10]. In contrast to the user clustering approach reported in Ref [9], a dynamic threshold for channel correlation criteria was applied. In addition, unlike the existing work in Ref. [11], the goal is to optimize the sum rate while keeping the users' fairness and energy limits in mind. Furthermore, dissimilar to the lagrangian approach-based power control strategy proposed in Ref. [12], a straightforward and extremely quick iterative power allotment component was presented. The research's contribution can be summarized as follows:

- To research the ghastly and energy execution of PC-H-BF, a minimal expense to some degree associated H-BF with a speedy assembly sub-par power allotment calculation, to address the key impediments of the non-orthogonal multiple access (NOMA) strategy, for example, intra and between pillar interference.
- Utilizing a low-intricity iterative boost technique, gather a lower valued mixture beamforming framework that incorporates a unique limit clients' gathering plan and is intended to place sub-optimal latent pillar and inter-beam and intra-beam dynamic power distribution tasks to augment measurements throughput.
- The effects of various system characteristics on spectral and energy performance were to be investigated.

## 2. MODEL OF THE SYSTEM

The downlink scenario in a multi-input single-output (MISO) – non-orthogonal multiple access (NOMA) based millimeter Wave architecture is addressed in this study, in which the base station is outfitted with enormous scope receiving wires (N-component) and various radio recurrence chains to help countless clients U, each with a solitary radio wire [13]. The suggested framework analyses a hybrid beamforming (H-BF) structure, as opposed to fully digital beamforming, which requires a specific handset chain (TX-chain) for every receiving wire component, expanding framework intricacy, in which the number of radio frequency chains is less than the number of available antenna elements, as shown in figure 1-(a).



**Figure 1.** Hybrid beamforming-based Downlink-NOMA system model [14].

Moreover, to keep things basic, a somewhat associated engineering was utilized, as represented in figure 1-(b), in light of the fact that each handset affix is simply associated with a subset of the accessible receiving wire components, a simple stage shifter network is required. The review accepts that the quantity of streams or pillars B is equivalent to the quantity of TX-chains, and that each stream can serve various clients utilizing non-symmetrical multiplexing.

### 3. THE PROBLEM FORMULA OF SPECTRAL EFFICIENCY (SE)

The minimal expense hybrid beamforming H\_BF method was matched with a unique edge clients' gathering plan to expand the non-symmetrical numerous entrance (NOMA)- millimeter Wave phantom proficiency, and afterward the figuring intricacy of the suggested arrangement was considered. There are various streams and numerous client hardware in each stream because of the presence of both the Intra-Beam and Intra-Beam Interference, i.e., there is collaboration and coupling between clients of different shafts. Accordingly, ideal answers for the power control issue are very challenging to go over. The issue's non convex optimisation strategy is tackled utilizing an iterative optimization approach, which brings about an awful arrangement. The issue of power control optimization can be expressed as follows [15].

$$\text{MAX}_p \sum_{m \in |s|} \sum_{n \in |s_{group}|} \log_2(1 + \text{SINR}_{mn}) \tag{1}$$

$$C^1: \log_2(1 + \text{SINR}_{mn}) \geq R_{mn}^{TH}, \quad \forall m, n \leftarrow \text{fairness performance for all user}$$

$$C^2: \sum_{m \in |s|} \sum_{n \in |s_{group}|} P_{mn} \leq P_t \leftarrow \text{Maximum power}$$

In this equation  $R_{mn}$  represents the data rate of the  $m^{th}$  client in the  $n^{th}$  stream,  $R_{mn}^{th}$  addressed the base rate (QoS) expected by the singular clients. The first imbalance  $C^1$  in quite a while guarantees fair execution for every one of the clients. The second disparity  $C^2$  is to save the all total power for the framework beneath or equivalent to the most extreme limit  $P_t$ .

### 4. PROPOSED USER PAIRING AND POWER CONTROL SCHEMES.

Clients bunches were thought of, and a matching capacity procedure for grouping clients with little it was proposed to process upward. Because of expanding channel data upward, concurrent various flagging is illogical to stretch out to all clients simultaneously in non-orthogonal multiple access (NOMA) frameworks [16 and 17]. Since clients in the cell are partitioned into various groups, non-orthogonal multiple access (NOMA) strategies can be sent effectively inside each bunch. A few plan highlights and execution hardships are looked by various client grouping calculations proposed in the writing. Increased channel gain Users appear to have higher power efficiency for the same amount of energy spent on the surface. Furthermore, users with higher link gains can

suppress more interference; for example, the client with the highest connection acquire in each bunch can suppress impedance from any remaining clients, whereas the client with the lowest connection acquire can't suppress any meddling indicators [18]. As a result, providing additional power to users in a cluster with high link gain will significantly increase data rate while also improving energy efficiency. Increased channel gain Users appear to have higher power efficiency for the same amount of energy spent on the surface. Furthermore, users with higher link gains can suppress more interference; for example, the client with the highest connection acquire in each bunch can suppress impedance from any remaining clients, whereas the client with the lowest connection acquire can't suppress any meddling indicators [18]. As a result, providing additional power to users in a cluster with high link gain will significantly increase data rate while also improving energy efficiency.

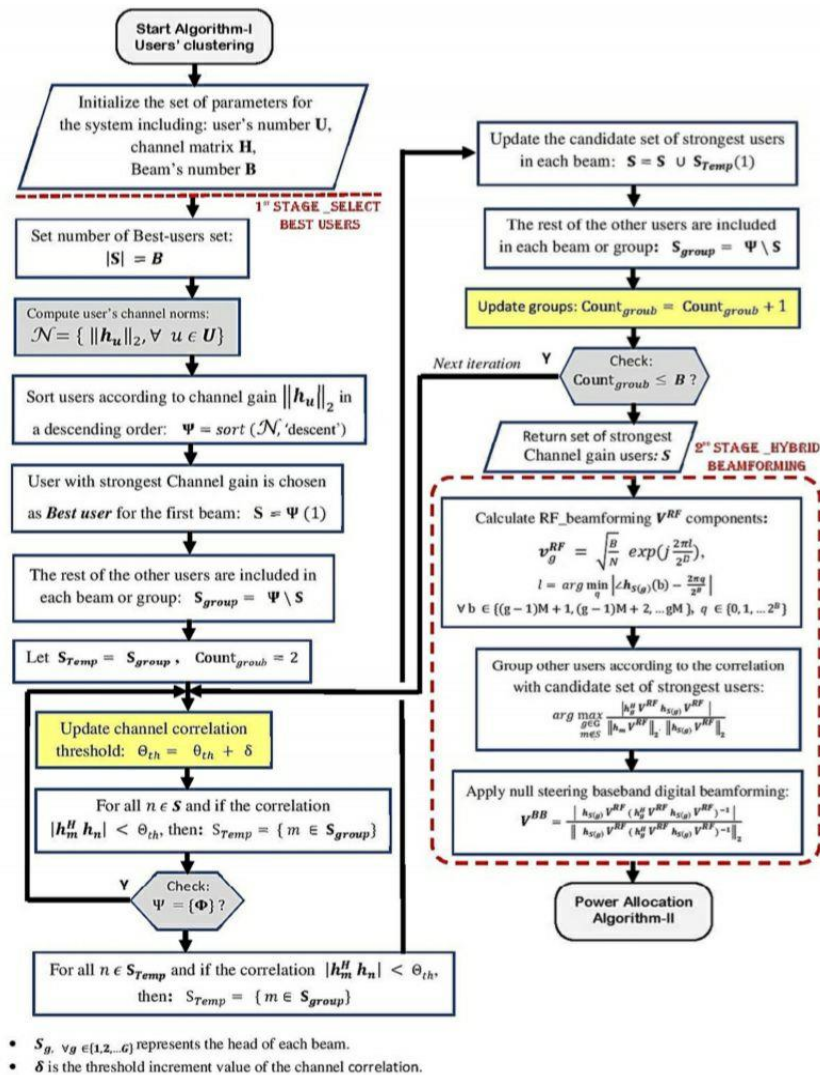


Figure 2. Algorithm I flowchart for the proposed clustering approach and hybrid beam formation

### 4.1. The equation of the flowchart

1. Initialize the set of parameters for the system including: user’s number U, channel matrix H, beam’s number B.
2. Compute user’s channel norms by using equation

$$N = \{ \|h_u\|_2, \forall u \in U \} \tag{2}$$

3. for all  $n \in S$  if the correlation with this condition

$$|h_m^H h_n| < \theta_{th}, \text{ then: } S_{Temp} = \{ m \in S_{group} \} \tag{3}$$

- 4- Calculate RF\_beamforming  $V^{RF}$  components:

$$v_g^{RF} = \sqrt{\frac{B}{N}} \exp(j \frac{2\pi l}{2^D}),$$

$$l = \arg \min_q \left| \angle h_{S(g)}(b) - \frac{2\pi q}{2^D} \right|$$

$$\forall b \in \{(g-1)M + 1, (g-1)M + 2, \dots, gM\}, q \in \{0, 1, \dots, 2^B\}$$
(4)

5- Other users are grouped based on their relationship to the candidate set of strongest users:

$$\arg \max_{\substack{g \in G \\ m \in S}} \frac{|h_g^H v^{RF} h_{S(g)} v^{RF}|}{\|h_m v^{RF}\|_2 \cdot \|h_{S(g)} v^{RF}\|_2}$$
(5)

6- Apply null steering baseband digital beamforming:

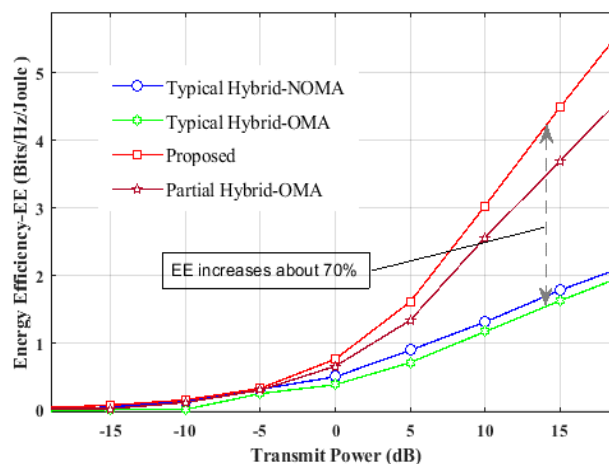
$$V^{BB} = \frac{|h_{S(g)} v^{RF} (h_g^H v^{RF} h_{S(g)} v^{RF})^{-1}|}{\|h_{S(g)} v^{RF} (h_g^H v^{RF} h_{S(g)} v^{RF})^{-1}\|_2}$$
(6)

### 5. RESULTS OF THE SIMULATION

In this section, the proposed clustering approach and power control technique were used to investigate the energy and spectral performances of downlink millimeter wave (mmWave)-non-orthogonal multiple access (NOMA) systems. The parameters of the suggested system were considered in our Matlab simulations in accordance with the requirements listed in Table I. In our simulation, we employed the following channel model for the mm-wave link.

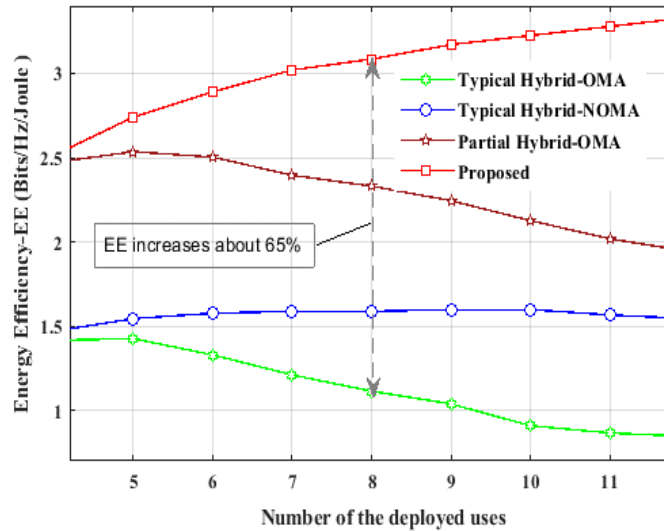
**Table I.** system parameters’ setting for numerical simulations.

Parameter	setting
Total transmit power	$P_t = 15$ dBm
Power loss in radio frequency chains	$p^{RF} = 25$ dBm
Power loss in base band network	$p^{BB} = 23$ dBm
Power loss in phase-shift network	$p^{PS} = 16$ dBm
Phase-shifters quantize digits (D)	5 bits
Channel model	The geometric Saleh-Valenzuela
Number of channel-path	3 (1-Line of sight LoS and 2-Non line of sight NLoS)
Base station antenna number	100 elements
Transceivers’ chain number	$N_{rf} = 4$ chains
Number of users’ clusters	4 (same as beam number)



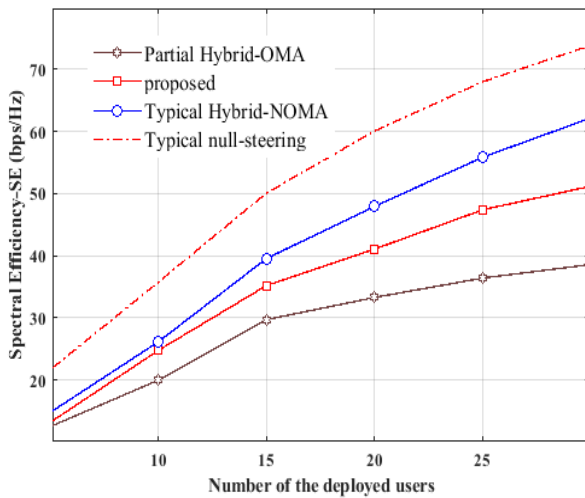
**Figure 3.** System performance in terms of energy efficiency verses transmits power.

On the other hand, Figure (3) shows the recommended strategy's advantages in terms of energy efficiency (EE)-performance, for example, it achieved an energy efficiency (EE)-gain of about 75% for 14 dB transmission powers when compared to the Partial Hybrid- OMA scenario, and thus Because of the basic phase-shifter network, energy waste was reduced to a minimum across all benchmarks.

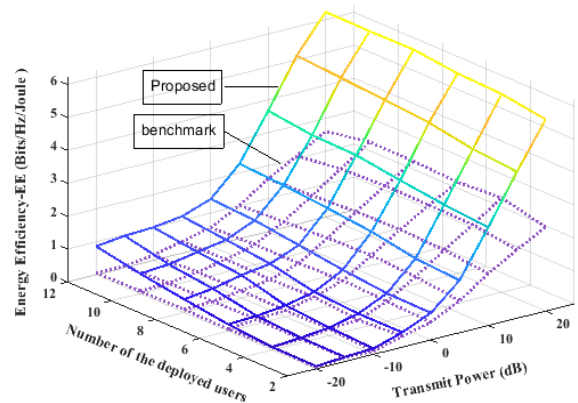


**Figure 4.**system performance in terms of energy efficiency verses number of the deployed users.

Figure (4) Presenting the impact of expanding the quantity of clients on energy proficiency (EE) at 1dB transmission power, it's obvious that the proposed framework generally beats others, it had an energy productivity (EE) gain of almost 65% when contrasted with the Partial Hybrid-orthogonal multiple access (OMA) situation for 8 clients.



**Figure 5.**system performance in spectral efficiency terms verses the number of deployed users.



**Figure 6.**system performance in terms of energy efficiency verses number of deployed users and the transmitted power.

In addition, the influence of the number of users on the spectral efficiency (SE)-performance of the network is depicted in figure (5). Furthermore, figure (6) Shows the impacts of both the number of clients and transmission power on the energy efficiency EE performance, obviously, the proposed system outperforms the baseline one i.e., "Typical Hybrid-NOMA" over all the range of compared parameters, and both of them raise with the increase of the maximum transmitting power.

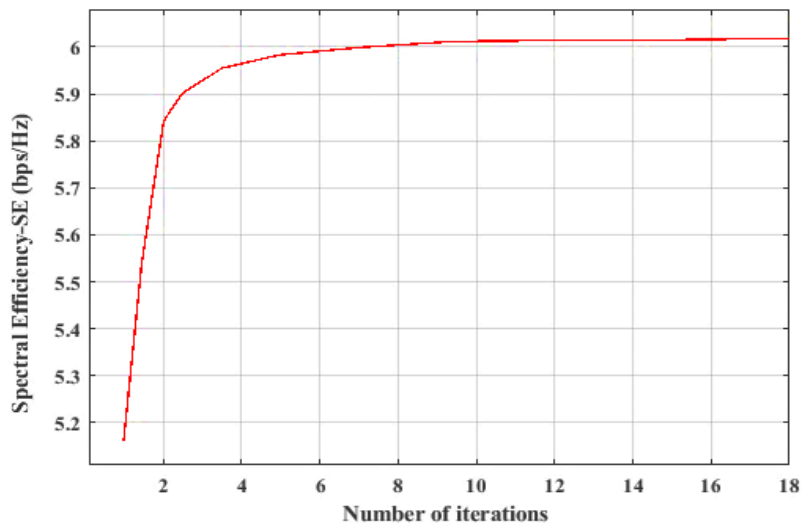


Figure 7. System performance in terms of SE versus the number of iterations.

Finally, figure (7) prove the converging speed of the proposed scenario as far as the number of cycles to accomplish the steady-state achievement of SE when it was adjusted parameters at 1 dB power budget and 8 users.

## 6. CONCLUSION

The link throughput improvement issue for non-orthogonal multiple access – millimeter-wave (mm-wave) methods is influenced by the total power budget and individual users' QoS limitations. The suggested technique includes a two-stage partially connected hybrid beamforming algorithm, as well as a basic iterative power control mechanism. The beamforming method allows for low-complexity success interference cancellation (SIC) at the receiver by utilizing efficient user selection for each beam. The power management algorithm generates a sub-optimal solution after a few cycles, converting the non-convex task into a tractable convex one. Numerical results back up the proposed technique's energy efficiency (EE) advantage. It is demonstrated that by using the provided method, Traditional schemes that use completely connected phase-shifter networks or orthogonal multiplexing have much lower EE performance.

## ACKNOWLEDGEMENTS

The authors gladly acknowledge the Wasit Police Directorate, through the Wasit Traffic Directorate, for their assistance in assembling the necessary crash data for the study.

## REFERENCES

1. Ngo, H. Q. (2015). *Massive MIMO: Fundamentals and system designs* (Vol. 1642). Linköping University Electronic Press.
2. IEEE J. Sel. Areas Commun., vol. 32, no. 6, pp. 1065–1082, Jun. 2014
3. Mumtaz, S., Rodriguez, J., & Dai, L. (2016). *MmWave massive MIMO: a paradigm for 5G*. Academic Press.
4. Kimy, B., Lim, S., Kim, H., Suh, S., Kwun, J., Choi, S., ... & Hong, D. (2013, November). Non-orthogonal multiple access in a downlink multiuser beamforming system. In *MILCOM 2013-2013 IEEE Military Communications Conference* (pp. 1278-1283). IEEE.
5. Ding, Z., Adachi, F., & Poor, H. V. (2015). The application of MIMO to non-orthogonal multiple access. *IEEE Transactions on Wireless Communications*, **15**(1), 537-552.
6. Choi, J. (2015). Minimum power multicast beamforming with superposition coding for multiresolution broadcast and application to NOMA systems. *IEEE Transactions on Communications*, **63**(3), 791-800.

7. Singh, J., & Ramakrishna, S. (2015). On the feasibility of codebook-based beamforming in millimeter wave systems with multiple antenna arrays. *IEEE transactions on Wireless Communications*, **14**(5), 2670-2683.
8. Gao, X., Dai, L., Han, S., Chih-Lin, I., & Heath, R. W. (2016). Energy-efficient hybrid analog and digital precoding for mmWave MIMO systems with large antenna arrays. *IEEE Journal on Selected Areas in Communications*, **34**(4), 998-1009.
9. Yu, X., Shen, J. C., Zhang, J., & Letaief, K. B. (2016). Alternating minimization algorithms for hybrid precoding in millimeter wave MIMO systems. *IEEE Journal of Selected Topics in Signal Processing*, **10**(3), 485-500.
10. Zhang, D., Wang, Y., Li, X., & Xiang, W. (2017). Hybridly connected structure for hybrid beamforming in mmWave massive MIMO systems. *IEEE Transactions on Communications*, **66**(2), 662-674.
11. Zheng, W., Koc, A., & Le-Ngoc, T. (2020, December). Sub-connected hybrid precoding architectures in massive MIMO systems. In *GLOBECOM 2020-2020 IEEE Global Communications Conference* (pp. 1-6). IEEE.
12. Chen, R., Shu, F., Lei, K., Wang, J., & Zhang, L. (2021). User Clustering and Power Allocation for Energy Efficiency Maximization in Downlink Non-Orthogonal Multiple Access Systems. *Applied Sciences*, **11**(2), 716.
13. Yuan, W., Kalokidou, V., Armour, S. M., Doufexi, A., & Beach, M. A. (2017, June). Application of non-orthogonal multiplexing to mmWave multi-user systems. In *2017 IEEE 85th Vehicular Technology Conference (VTC Spring)* (pp. 1-6). IEEE.
14. Alraddady, F., Ahmed, I., & Habtemicaïl, F. (2021). Robust Hybrid Beam-Forming for Non-Orthogonal Multiple Access in Massive MIMO Downlink. *Electronics*, **11**(1), 75.
15. Gao, D. Y., & Sherali, H. D. (Eds.). (2009). *Advances in applied mathematics and global optimization: In honor of Gilbert Strang* (Vol. 17). Springer Science & Business Media.
16. Liu, P., Li, Y., Cheng, W., Zhang, W., & Gao, X. (2019). Energy-efficient power allocation for millimeter wave beamspace MIMO-NOMA systems. *IEEE Access*, **7**, 114582-114592.
17. Islam, S. R., Zeng, M., Dobre, O. A., & Kwak, K. S. (2018). Resource allocation for downlink NOMA systems: Key techniques and open issues. *IEEE Wireless Communications*, **25**(2), 40-47.
18. Benjebbour, A., Saito, Y., Kishiyama, Y., Li, A., Harada, A., & Nakamura, T. (2013, November). Concept and practical considerations of non-orthogonal multiple access (NOMA) for future radio access. In *2013 International Symposium on Intelligent Signal Processing and Communication Systems* (pp. 770-774). IEEE.
19. Ding, Z., Dai, L., & Poor, H. V. (2016). MIMO-NOMA design for small packet transmission in the Internet of Things. *IEEE access*, **4**, 1393-1405.